



EstesRockets.com

CELESTIAL EXPLORER™

0689

AGES
10+



Skill Level

BEGINNER

MODEL ROCKET INSTRUCTIONS

KEEP FOR FUTURE REFERENCE

IMPORTANT: Please record date found on decal and keep for future reference. _____

Read all instructions. Make sure you have all parts and supplies.

SUPPLIES



PLASTIC CEMENT

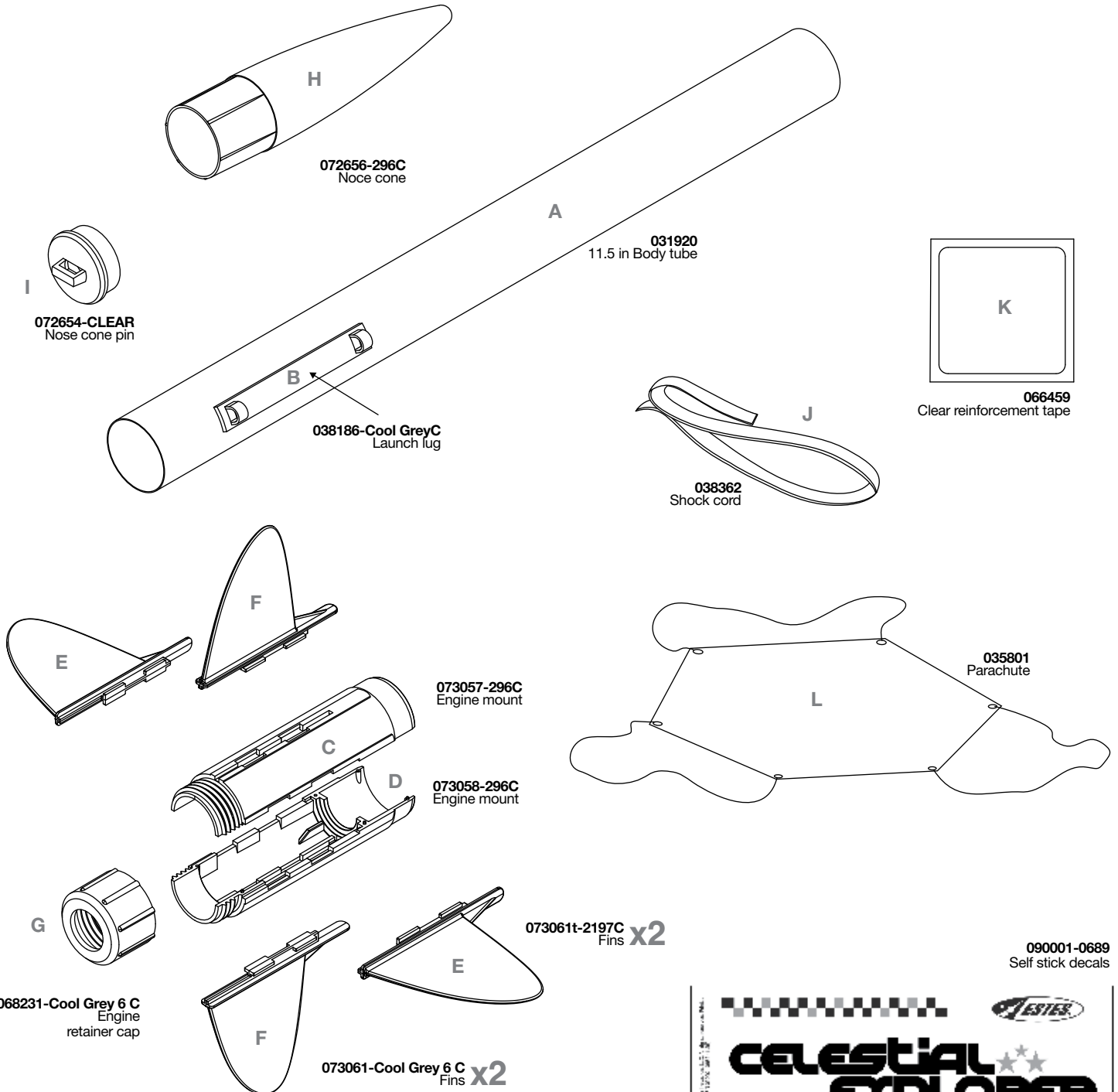

ASSEMBLE ENGINE MOUNT AND FINS

1. Apply plastic cement to the edges of **D**.

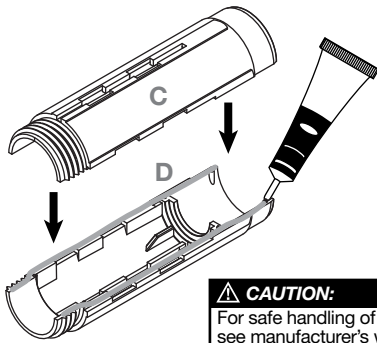

2. Press **C** and **D** together.

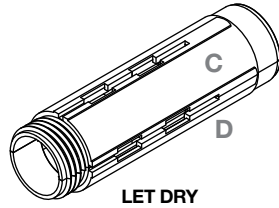

CAUTION:
For safe handling of plastic cement, see manufacturer's warnings and follow instructions for use.

3. Insert fin **E** into slot in engine mount **C/D**.

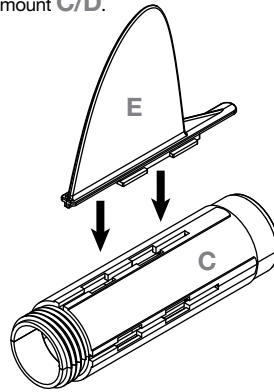

4. Slide fin forward to lock into place.

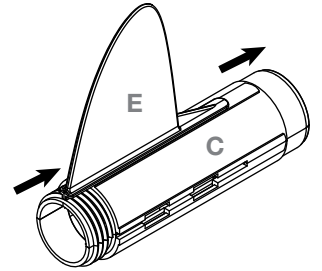

5. Repeat for all 4 fins.

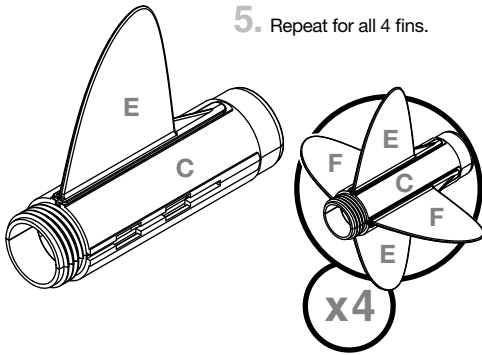

6.

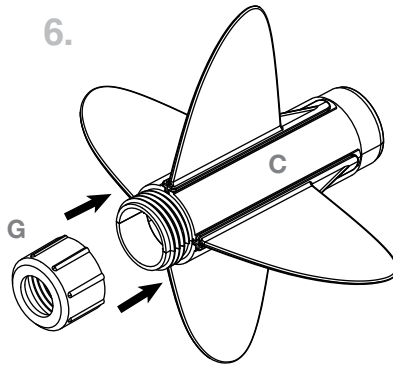

7. Screw engine retainer cap **G** onto engine mount **C/D**.

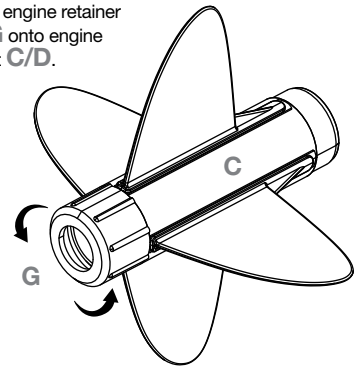

ATTACH BODY TUBE TO ENGINE MOUNT

1. Pull shock cord **J** out of the front of body tube **A**.

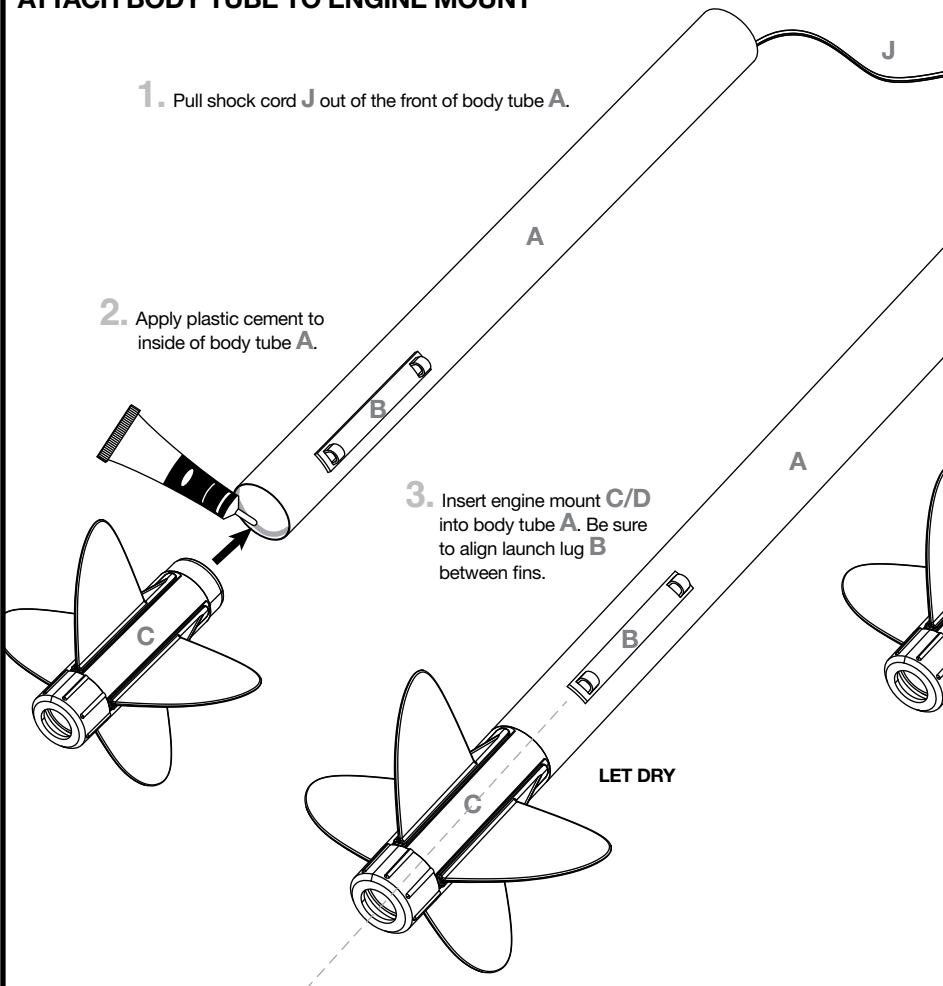

2. Apply plastic cement to inside of body tube **A**.

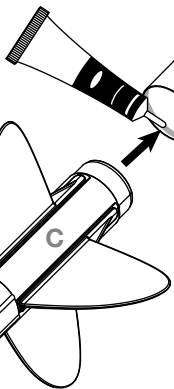

3. Insert engine mount **C/D** into body tube **A**. Be sure to align launch lug **B** between fins.

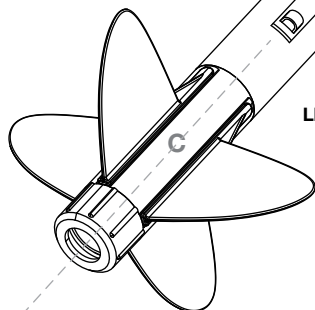

4. Place clear reinforcement tape **K** over launch lug **B**.

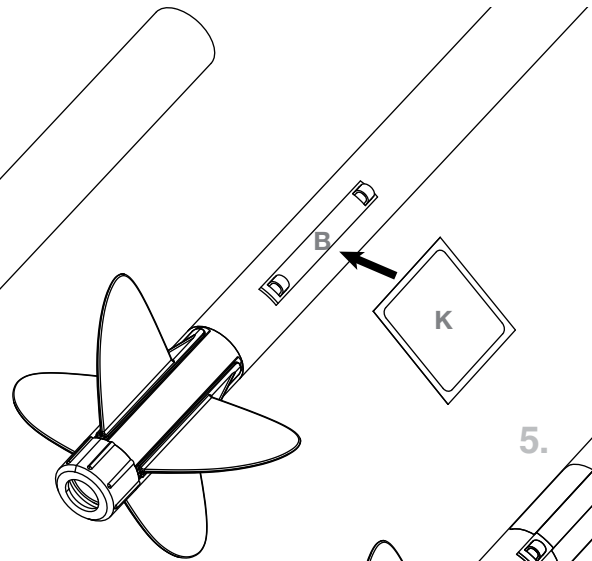

5.

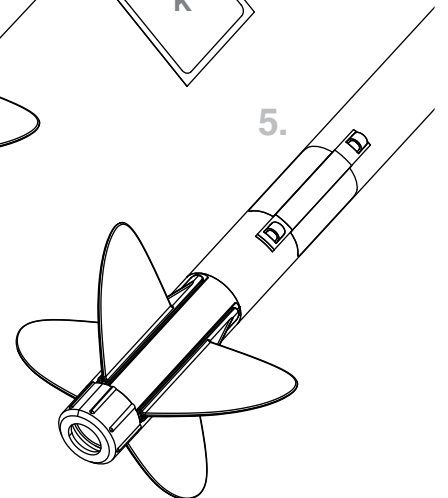

ASSEMBLE NOSE CONE

1. Apply plastic cement to the inside of nose cone **H** and insert nose cone pin **I**.

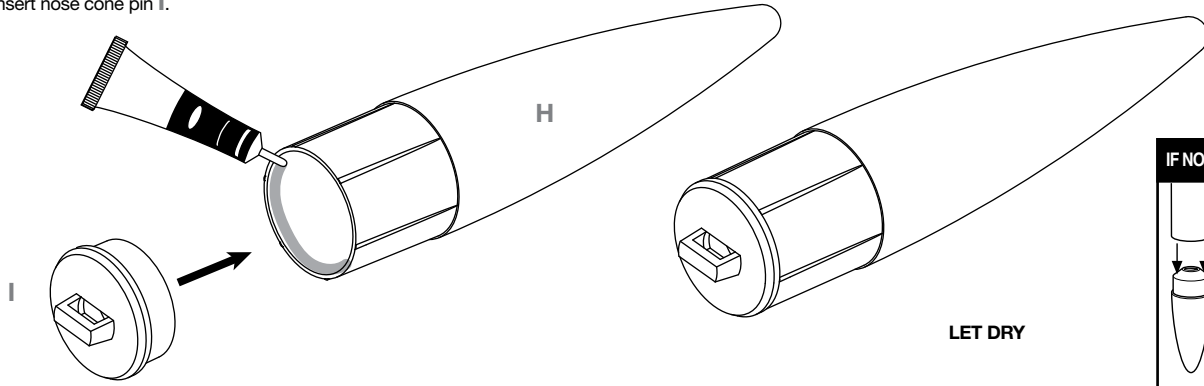

LET DRY

IF NOSE CONE FIT IS...

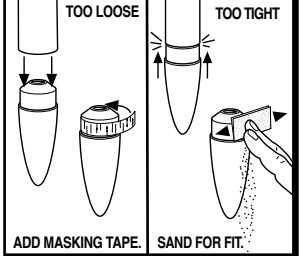

INSTALL RECOVERY SYSTEM

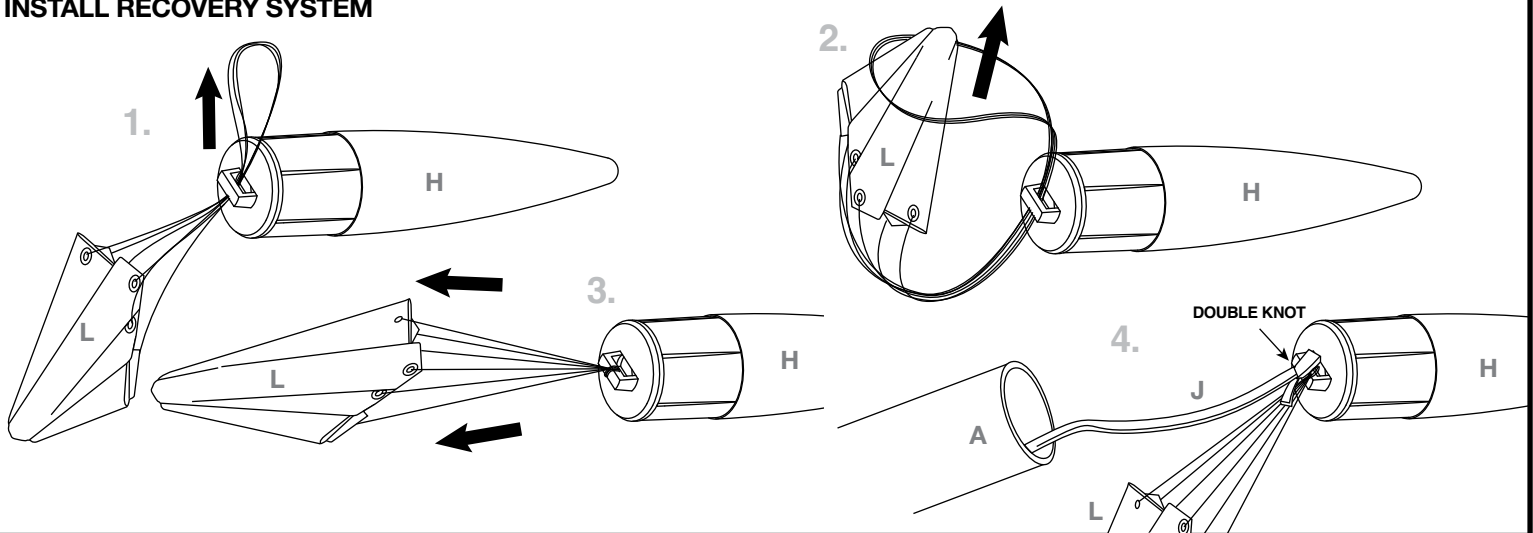

PREPARE FLIGHT RECOVERY

1. Push recovery wadding down towards end of the body tube.

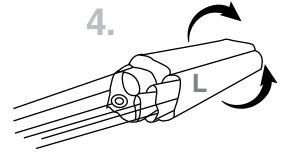
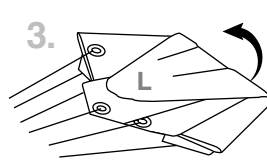
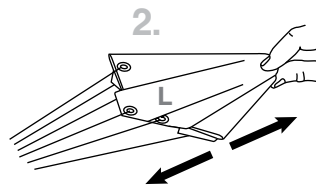
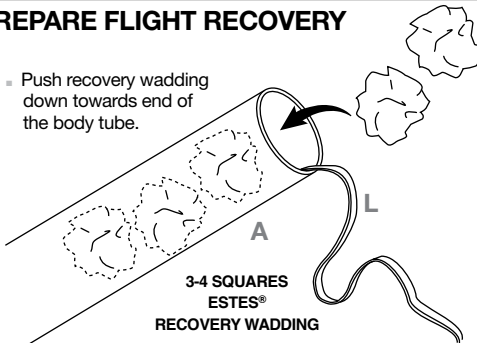

5. Wrap parachute shroud lines loosely around the parachute **N** and insert into body tube **A**.

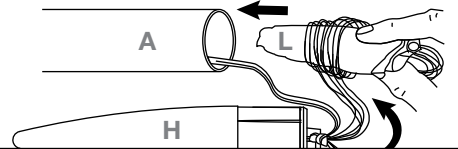

PREPARE ENGINE

1. Use one each.

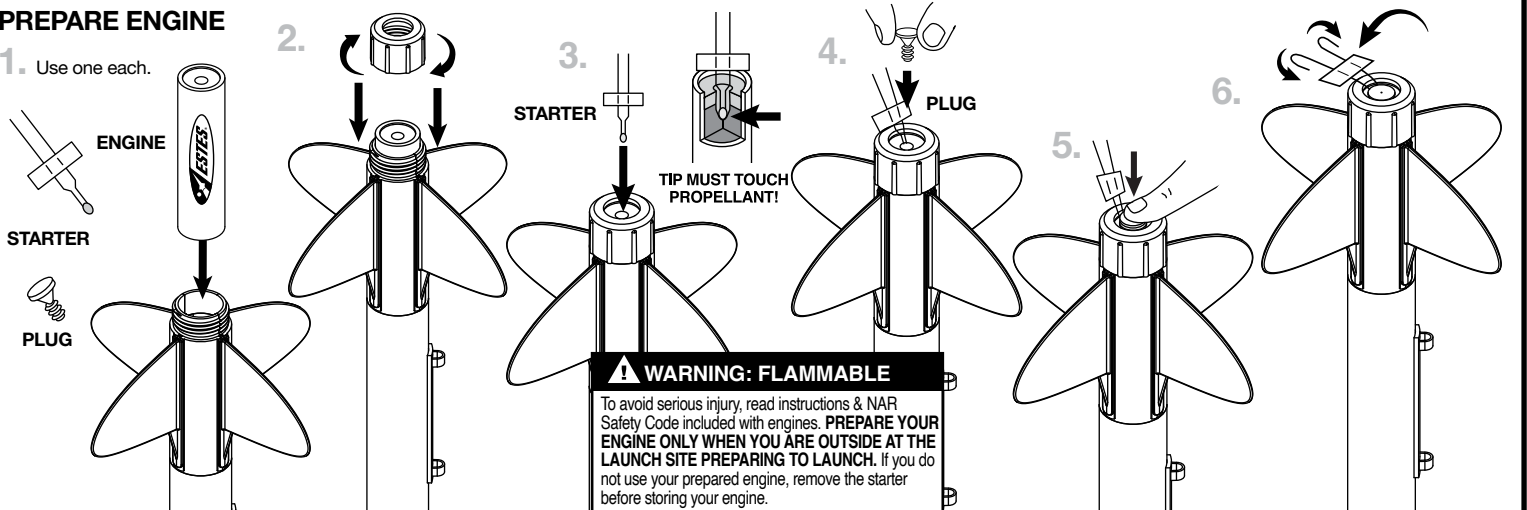

⚠ WARNING: FLAMMABLE

To avoid serious injury, read instructions & NAR Safety Code included with engines. **PREPARE YOUR ENGINE ONLY WHEN YOU ARE OUTSIDE AT THE LAUNCH SITE PREPARING TO LAUNCH.** If you do not use your prepared engine, remove the starter before storing your engine.

NOTE:
Always keep the key **OUT** until final countdown.

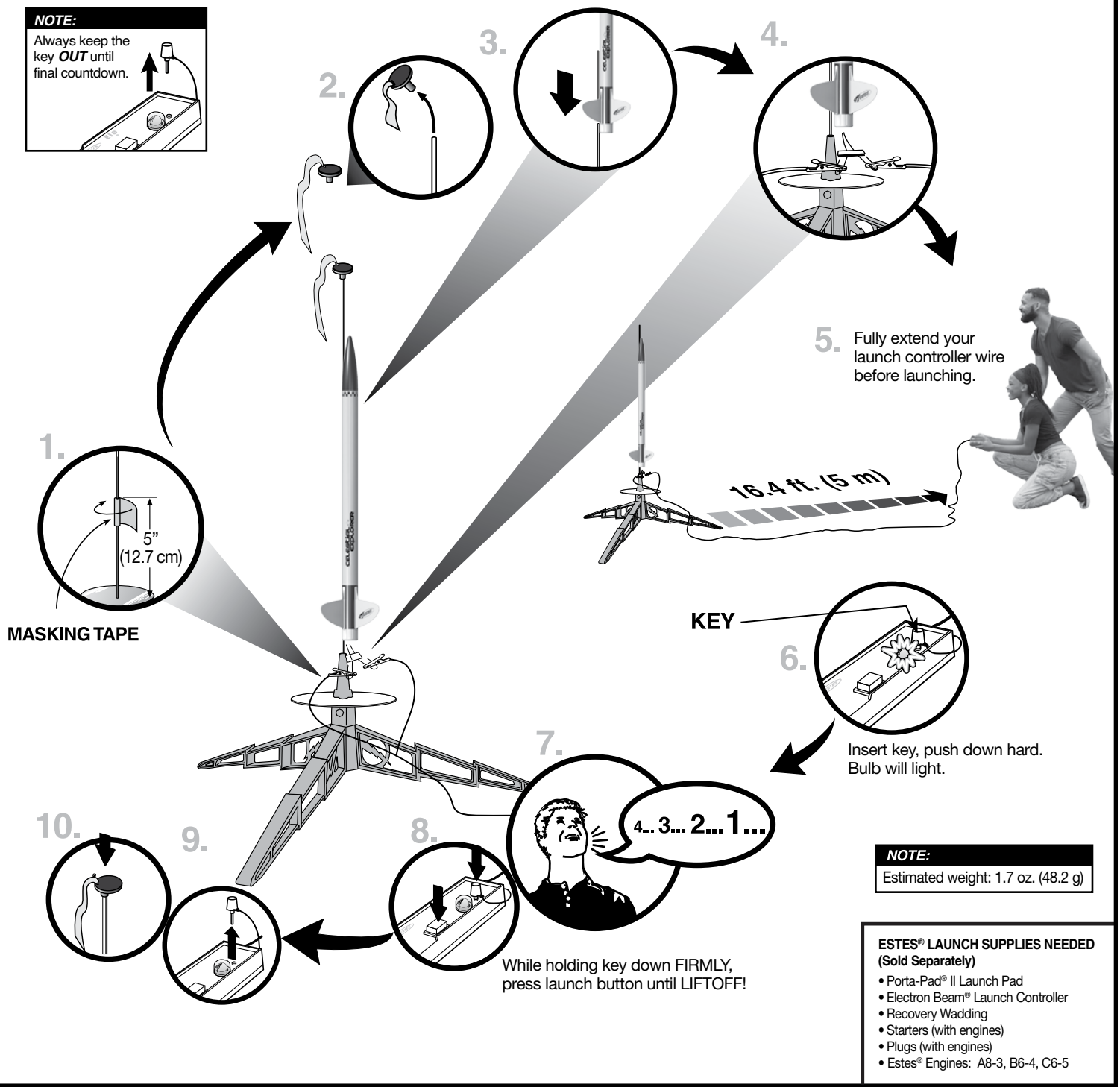

NOTE:
Estimated weight: 1.7 oz. (48.2 g)

- ESTES® LAUNCH SUPPLIES NEEDED (Sold Separately)**
- Porta-Pad® II Launch Pad
 - Electron Beam® Launch Controller
 - Recovery Wadding
 - Starters (with engines)
 - Plugs (with engines)
 - Estes® Engines: A8-3, B6-4, C6-5

PRECAUTIONS



NAR SAFETY CODE



NO DRY GRASS OR WEEDS

PRE-LAUNCH CHECK For safety, never launch a damaged rocket. Check the rocket's body, nose cone and fins. Also, check the engine mount, recovery system and launch lug(s). Repair any damage before launching the rocket.

FLYING YOUR ROCKET Choose a large field (500 ft. [152 m] square) free of dry weeds and brown grass. The larger the launch area, the better your chance of recovering your rocket. Launch only with little or no wind and good visibility. Always follow the National Association of Rocketry (NAR) SAFETY CODE (enclosed).

MISFIRES TAKE THE KEY OUT OF THE CONTROLLER. WAIT ONE MINUTE BEFORE GOING NEAR THE ROCKET. Disconnect the micro-clips and remove the engine. Take the plug and starter out of the engine. A burned starter means the starter tip was not touching engine propellant. Install a new starter; be sure the tip is touching propellant inside the engine. Push the plug in place. Repeat steps under Countdown and Launch.

